



# Operations Manual

Eagle T100SM Carton Sealer



**READ ALL INSTRUCTIONS CONTAINED IN THIS  
MANUAL PRIOR TO MACHINE INSTALLATION!**

# Contents

	<i>page</i>
<b>1. Safety &amp; Warnings</b>	<b>3</b>
<b>2. Specifications</b>	<b>4</b>
<b>3. Setup and Installation</b>	<b>5</b>
3.1 Machine Transportation	5
3.2 Work Height	5
3.3 Tape Head Installation	5
3.4 Upright Post Assembly	6
3.5 Extension Table Installation	6
3.6 Power Supply	6
<b>4. Operation</b>	<b>7</b>
4.1 Standard Operation	7
4.2 Work Height Adjustment	7
4.3 Adhesive Tape Feed	8
4.4 Adjusting Tape Length	8
4.5 Top Box Squeezer Adjustment	8
<b>5. Maintenance &amp; Troubleshooting</b>	<b>9</b>
5.1 Regular Maintenance	9
5.2 Lubrication	9
5.3 Conveyor Belt Adjustment	9
5.4 Carriage Height Adjustment	10
5.5 Conveyor Width Adjustment	10
5.6 Typical Faults & Solutions	11
<b>6. Illustrations &amp; Parts List</b>	<b>12</b>
6.1 Replacement Parts	12
6.2 Main Frame Components	13
6.3 Upright Post Assembly	14
6.4 Tape Head Carriage	15
6.5 Side Conveyor System	16
6.6 Top Box Squeezer	18
6.7 Conveyer Roller	19
6.8 Tape Head Assembly	19
6.9 Front Tape Roller Assembly	21
6.10 Back Roller Side Plate	22
6.11 One-Way Knurled Roller Assembly	23
6.12 Guide Pulley Assembly	23
6.13 Knife Back Plate Assembly	24
6.14 Tape Head Assembly	25
6.15 Guide Tape Wheel Assembly	25
6.16 Tape Holder Assembly	26
6.17 Tape Guide Assembly	26

## 1. Safety and Warnings



**WHILE OPERATING THE MACHINE, OPERATORS MUST REFRAIN FROM WEARING CLOTHING OR ACCESSORIES THAT MAY GET CAUGHT IN THE MOVING PARTS OF THE MACHINE (WATCHES, RINGS, BRACELETS, TIES, LOOSE CLOTHING, ETC...)**

The Eagle T100 is an automatic case sealing machine using pressure-sensitive tape such as PVC or BOPP.

This machine has a wide range of applications including the following industries: chemical fiber, pharmaceutical, publication, refrigeration and air-conditioning, household appliances, ceramics, produce, meats, poultry.

Prior to setting up the machine

1. Verify the model number matches the model number addressed in this manual.
2. Verify that no parts of the machine have been removed or are missing.
3. Remove all packaging or shipping materials used during transport or storage of the machine.
4. Check for any damage that may have occurred during shipping or transport.

Prior to operating the Eagle T100, verify

- Protective shielding and covers are properly installed
- Top and side transfer rollers are present and properly installed
- Machine is on stable ground and casters are in the locked position.

The Eagle T100 is designed to automatically shut down if the control panel is opened while the machine is in operation.



**DO NOT USE TO SEAL CARTONS CONTAINING HAZARDOUS SUBSTANCES OR EXPLOSIVE MATERIALS**

## 2. Specifications

Power Requirement	110VAC, 50/60Hz (Single Phase)
Sealing Speed	30 cartons per minute
Max. Carton Weight	80lbs (36kg)
Tape Width	2-3in (48-72mm)
Carton Length	6in to infinite
Carton Width	3.75-11.75in
Carton Height	3-18.50in
Machine Length	43in
Machine Width	32in
Machine Height	50.3in
Weight	507lbs
Operational Environment	32-104°F (0-40°C) @ ≤ 98% Humidity
Machine Noise Levels	≤ 75db

### 3. Machine Setup and Installation



**TAKE CARE TO AVOID DAMAGE TO THE MOTOR AND ASSEMBLY WHILE LIFTING OR TRANSPORTING THE MACHINE!**

#### 3.1 Transportation

Use a fork lift or tow motor to remove the machine from its shipping container or pallet.

#### 3.2 Working Height Adjustment

While elevated, install the adjustable legs onto the machine. Set each leg to the same height to ensure the machine is level when placed onto the ground.

The working height should be set such that the operator is able to comfortably reach the roller table while maintaining approximately 4in (100mm) of distance from the machine.

#### 3.3 Tape Head Installation

Rest the upper tape head on the carriage placing the notches in the rear of the tape head onto the supporting shaft. Pull out the draw rod by the key ring, lower the tape head and release the key ring. For the lower tape head, remove the front supporting shaft. Rest the rear of the tape head on the rear supporting shaft. Place the front supporting shaft on the angled notches in the front of the tape head and lower the tape head down guiding the pin into the notches in the frame.



Check tape cutter position and adjust as needed.

### 3. Machine Setup and Installation

#### 3.4 Upright Post Assembly

Attach upright post assembly to the base frame with the screws provided

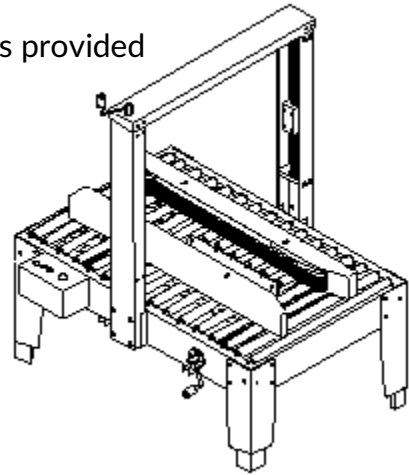
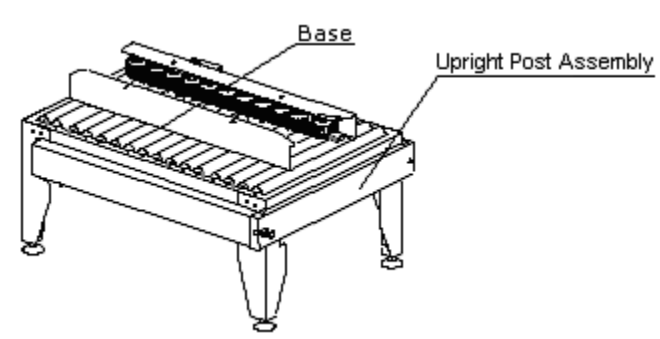

#### 3.5 Extension Table Installation

Align the holes in the extension with the posts in the frame and carefully lower the table extension.

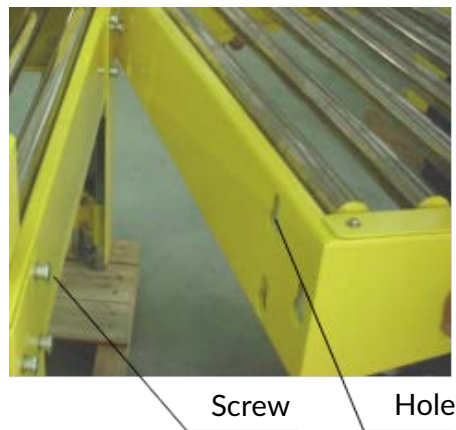

#### 3.6 Connect Power Supply

Connect the machine to the power supply.

Note: Prior to connecting the machine to the power supply, verify that the power switch is set to the 'OFF' position and that the work area is clean and clear of any items.

## 4. Operation

### 4.1 Standard Operation

Prior to operating the machine, please confirm that

1. The proper voltage is being supplied to the motor
2. All fasteners and protective covers are securely in place
3. All electronic components are dry

Machine Operation

1. Plug the machine into the power source
  - a. DO NOT hard wire the machine to the power source
2. Adjust horizontal and vertical guides to accommodate cartons to be sealed
3. Press the button labeled 'Start'
4. Verify belt movement direction
5. Place carton to be sealed into the feed side of the machine
  - a. Cartons must be placed in the center of the roller table for proper feed through the machine

After operating the machine for two to five minutes, check the following

1. Horizontal guide adjustment lever is firmly in place and belts do not have excess slack
  - a. Belt deviation (slack) should be checked once every ten days
  - b. Adjust belt tension as needed
2. Vertical guide adjustment lever is firmly in place
3. Verify that tape is being dispensed in a consistent manner that ensures a smooth application onto the carton being fed through the machine.



**TURN OFF MACHINE AND DISCONNECT IT FROM THE POWER SOURCE PRIOR TO PERFORMING ANY MAINTENANCE OR SERVICE**

### 4.2 Adjustable Work Height

Put the nut plate into the leg support according to the figure.

Then loosely connect the fastening piece and the nut plate with the socket head cap screws. Insert the leg between the leg support and nut plate. The leg can now be adjusted up and down as desired. Tighten the screws.

The working height should be set such that the operator is able to comfortably reach the roller table while maintaining approximately 4in (100mm) of distance from the machine.

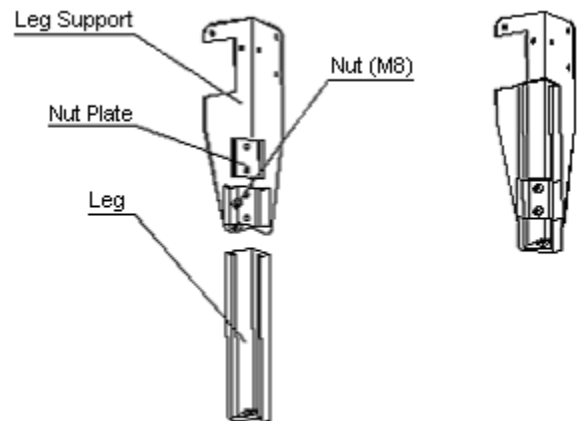

## 4. Operation

### 4.3 Feeding the Adhesive Tape

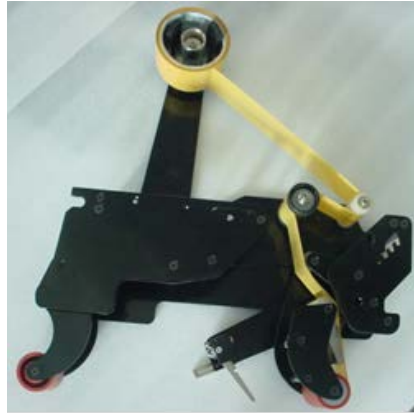

### 4.4 Adjusting Tape Length

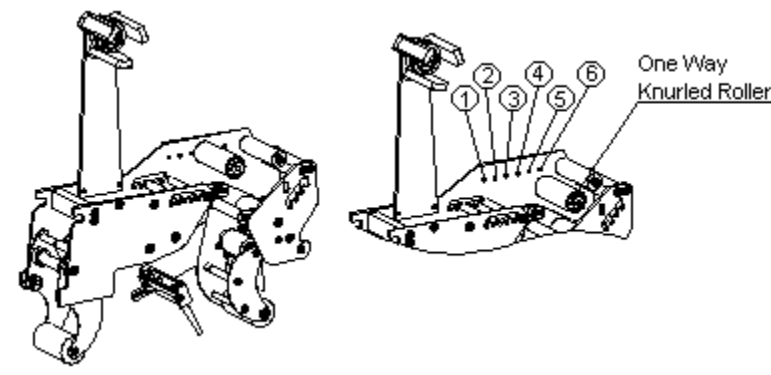

Move the guiding tape wheel from hole #1 to hole #6 to shorten the tape length.

### 4.5 Top Box Squeezer Adjustment

Loosen the knobs and move each top box squeezer in the direction of the arrows 1 and 2, keeping the rollers close to the case tighten the knobs.

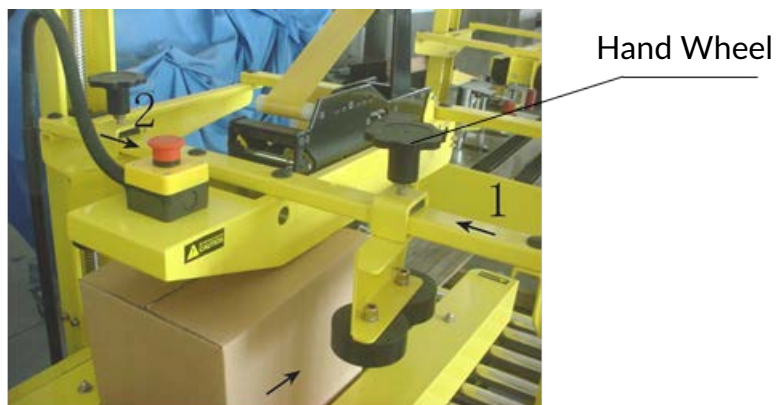



## 5. Maintenance and Troubleshooting



**TURN OFF MACHINE AND DISCONNECT IT FROM THE POWER SOURCE PRIOR TO PERFORMING ANY MAINTENANCE OR SERVICE**

### 5.1 Regular Maintenance & Cleaning

1. Check all bolts and screws regularly to ensure smooth, malfunction-free operation of the machine.
2. Lubricate moving parts of the machine on a regular basis.
3. Clean the machine surfaces.
4. Clean off any tape residue from the cutting blade daily.
5. If the machine is to be stored for an extended period of time, the cutting blade should be oiled prior to being placed in storage.

### 5.2 Lubrication

1. The driving chain should be lubricated once a month.
2. The bearings should be lubricated once a month.
3. The transmission axle, driving chain and bearing should be lubricated once a week.
4. All other moving parts should be lubricated on a regular basis.

### 5.3 Conveyor Belt Adjustment

Adjustments are made using the adjustable bolt located at the end of the side conveyor system.

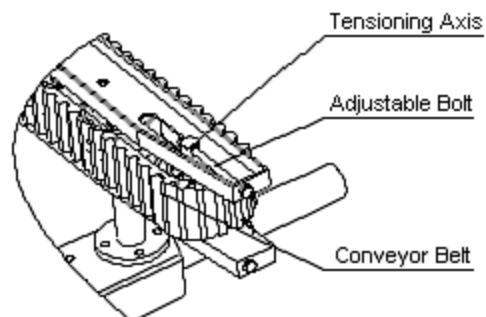

## 5. Maintenance & Troubleshooting

### 5.4 Carriage Height Adjustment

Rotate the height adjustment handle by hand to adjust the carriage height.

Rotate the handle clockwise to move the carriage up and counter clockwise to move the carriage down.

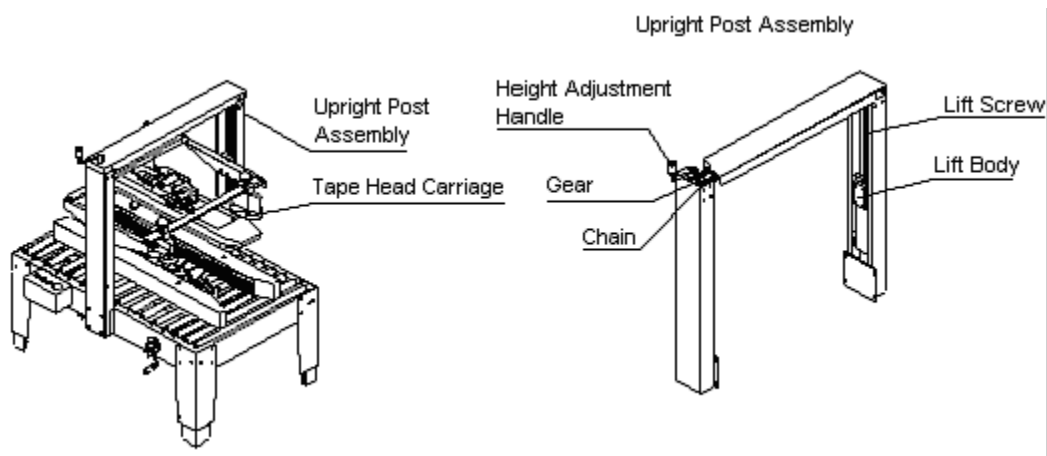

### 5.5 Conveyor Width Adjustment

Rotate the width adjustment handle by hand to adjust the conveyor width. Rotate the handle clockwise to decrease the distance between the conveyors. Rotate the handle counter clockwise to increase the distance between the handles.

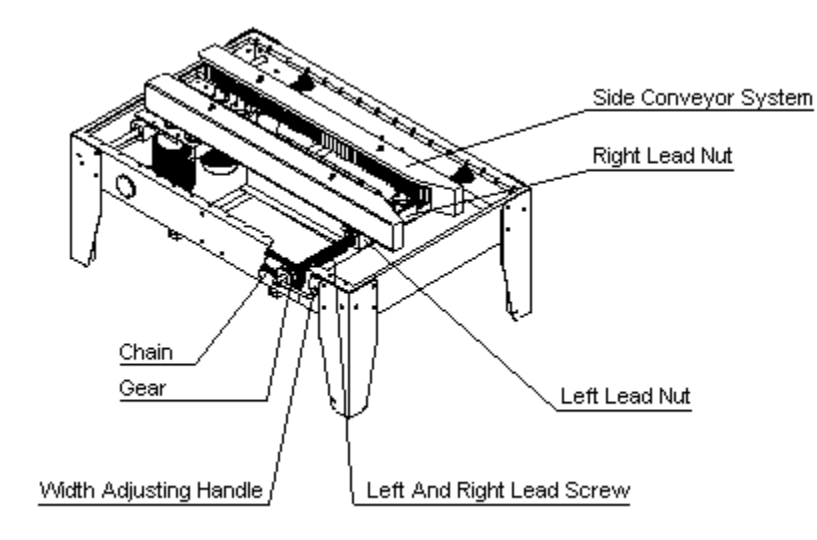

## 5. Maintenance & Installation

### 5.6 Typical Faults & Solutions

Fault	Solution
Tape is not centered on the carton.	Adjust the tape positioning knob on the tape head dispenser.
Scratched carton caused by tape cutting blade.	Adjust tape cutting blade position.
Tape is not properly adhering to the carton. (Caused by forward tape transfer wheel not applying sufficient force)	Adjust front wheel spring to increase force.

## 6. Illustrations & Parts List

### 6.1 Replacement Parts

	Description	Part Number	Qty
	Roller Assembly		-
	Belt		-
	Chain	06B	-
	Wheel	FJG-1A-149	-
	Drive Roller	FJG-1A-148	-

## 6. Illustrations & Parts List

### 6.2 Main Frame Components

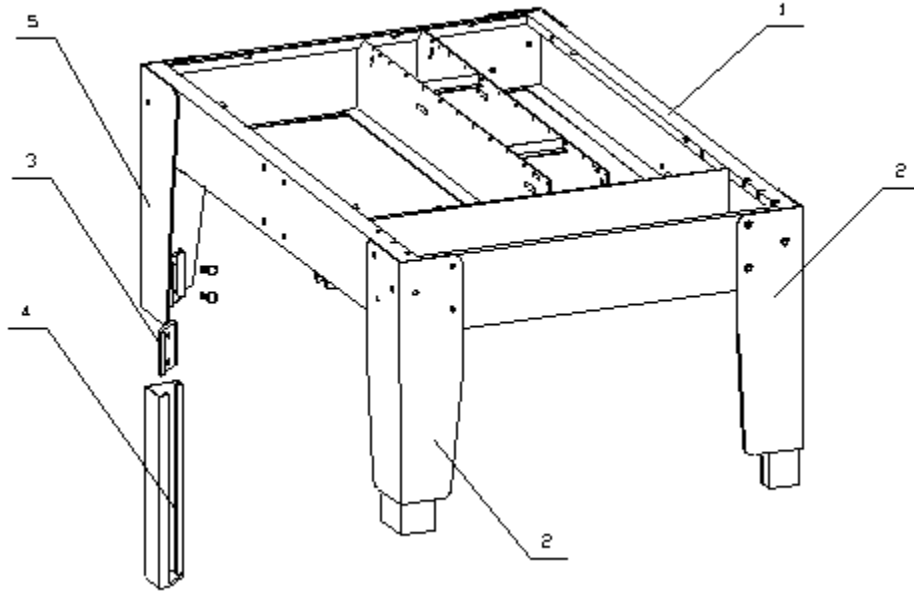

	Description	Part Number	Qty
1	Machine Frame		1
2	Front Leg Support	FJG-1A-110	2
3	Nut Plate	FJG-1A-112	4
4	Leg	FJG-1A-113	4
5	Rear Leg Support	FJG-1A-111	1/ea

## 6. Illustrations & Parts List

### 6.3 Upright Post Assembly

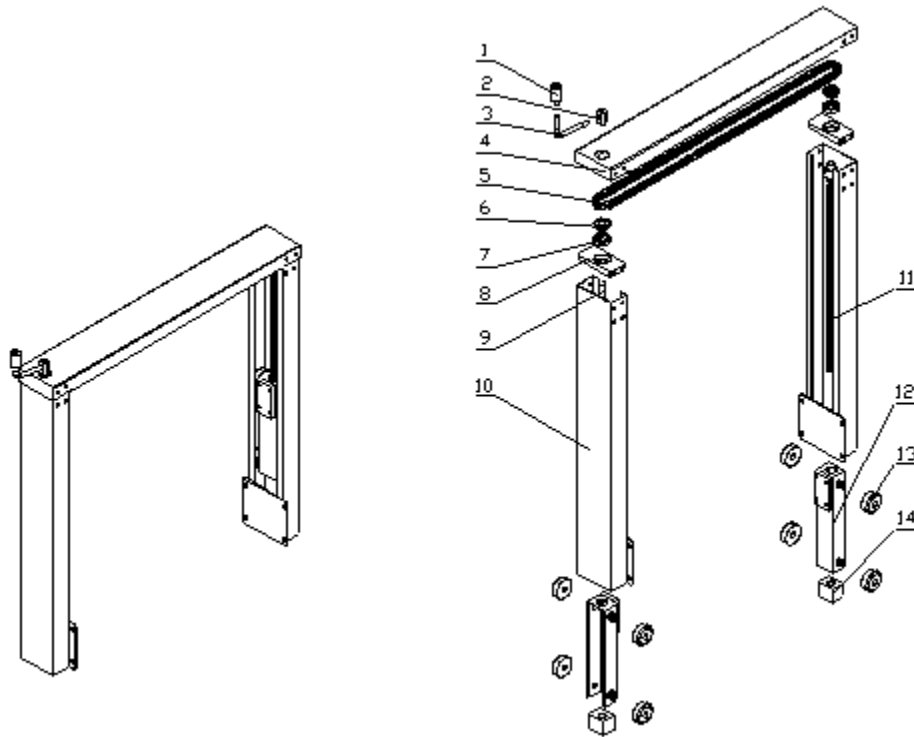

	Description	Part Number	Qty
1	Handle	FJG-1A-193	1
2	Hub	FJG-1A-944	1
3	Handle Mount	FJG-1A-917	1
4	Beam		1
5	Chain	06B	1
6	Height Adjustment Gear	FJG-1A-179	2
7	Lift Screw Bearing	6905-2Z	2
8	Upper Supporting Board	FJ-3AS-21	2
9	Lift Screw (Left)	FJ-3AS-26	1
10	Upright Post Body		2
11	Lift Screw (Right)	FJ-3AS-25	1
12	Lift Body	FJ-3AS-19	2
13	Idler Wheel	FJ-1B-11	8
14	Nut	FJ-3AS-20	2

## 6. Illustrations & Parts List

### 6.4 Tape Head Carriage

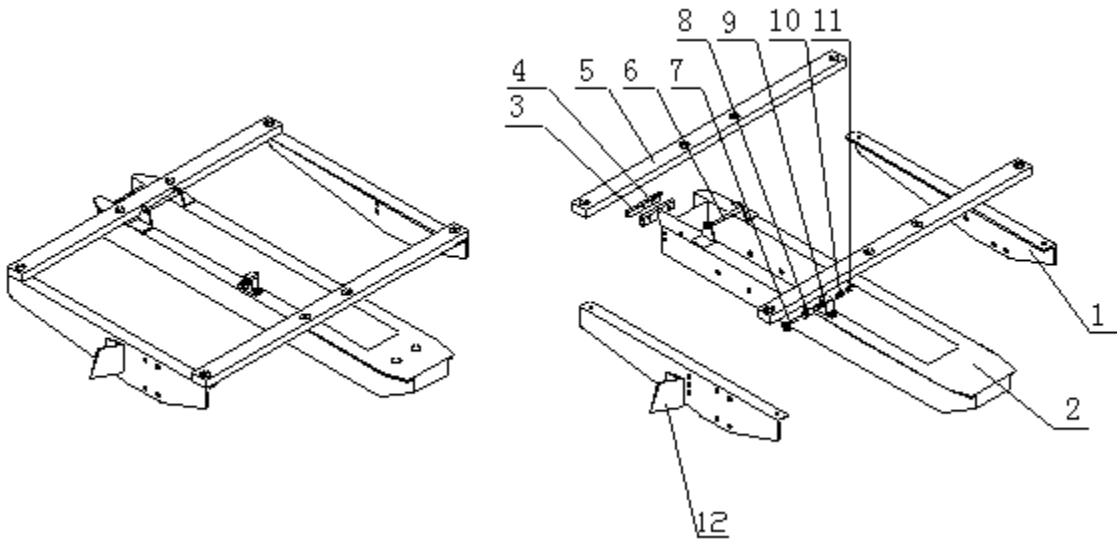

	Description	Part Number	Qty
1	Bracket	FJG-1A-130	2
2	Motor Support	FJ-1A-120	1
3	Retaining Plate	FJ-1A-703	1
4	Brush Support	FJ-1A-701	1
5	Support Bars		2
6	Supporting Shaft	FJ-1-440	1
7	Shaft	FJ-3A-807	1
8	Spring Holder	FJ-3A-808	1
9	Fixed Block	FJG-1A-127	1
10	Compression Spring	FJ-1A-930	1
11	Sliding Block	FJ-3A-806	1
12	Pointer	-	1

## 6. Illustrations & Parts List

### 6.5 Side Conveyor System

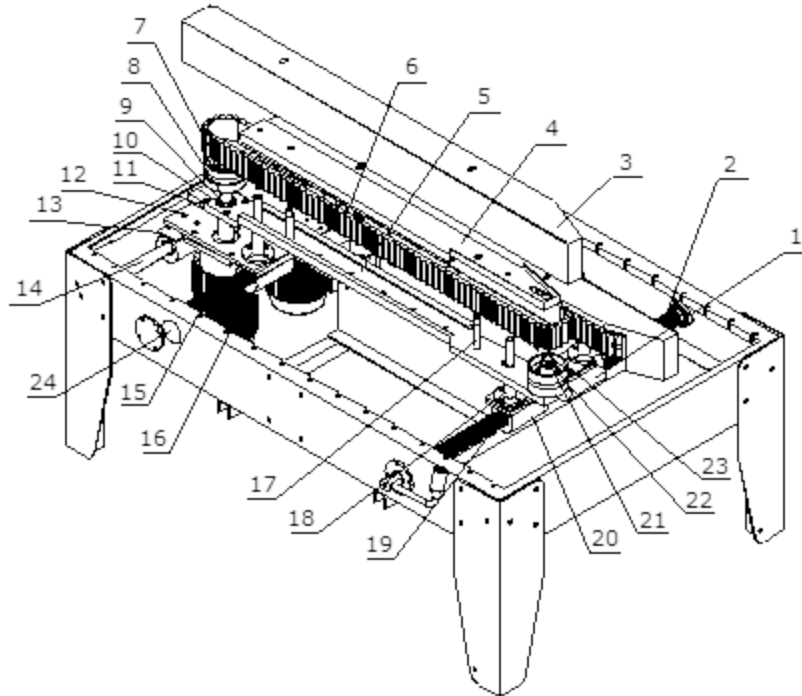
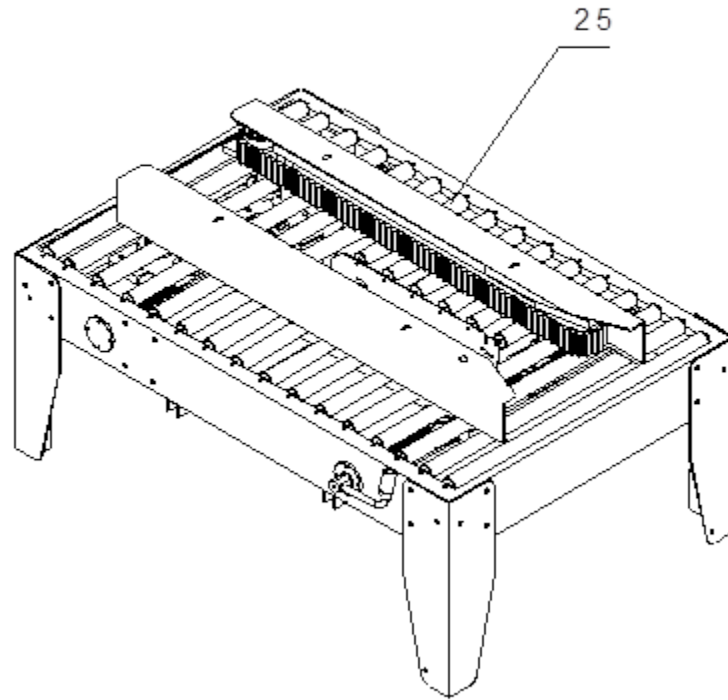



## 6. Illustrations & Parts List

### 6.5 Side Conveyor System (Continued)

	Description	Part Number	Qty
1	Right Lead Nut	FJG-1A-927	2
2	Lead Screw (Left/Right)	FJG-1A-155	1
3	Cover Plate	FJG-1A-169	1/ea
4	Side Belt Cover	FJG-1A-152	1/ea
5	Conveyor Support Base	FJG-1A-151	1/ea
6	Belt	1,867mm	2
7	Drive Roller	FJG-1A-148	2
8	Transmission Shaft	FJ-1A-200	2
9	Driver Wheel Sleeve	FJG-1A-208	2
10	Conveyor Bearing	6005	2
11	Bearing Base	FJG-1A-153	2
12	Motor Mount Panel	FJ-1A-302	2
13	Sliding Sleeve	FJ-1A-920	2
14	Guide Shaft	FJ-1A-201	1
15	Lead Screw (Left/Right)	FJG-1A-154	1
16	Motor	CV200-20ZG1/G2	2
17	Locating Pins	FJG-1A-160	4
18	Connection Pole	FJG-1A-162	4
19	Orientation Plate	FJG-1A-158	2
20	Left Lead Nut	FJG-1A-156	2
21	Tensioning Shaft	FJG-1A-141	2
22	Tension Wheel Sleeve	FJG-1A-207	4
23	Wheel	FJG-1A-149	2
24	Width Adjustment Gear	FJG-1A-192	2
25	Roller Assembly	FJG-1A-182/183	-

## 6. Illustrations & Parts List

### 6.6 Top Box Squeezer

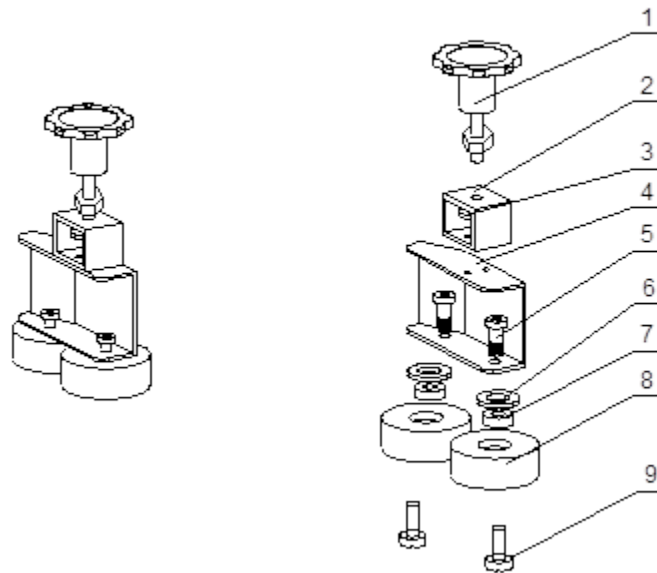

	Description	Part Number	Qty
1	Knob	FJG-1A-197	1
2	Locking Frame	FJG-1A-194	1
3	Backing Guard	FJG-1A-943	1
4	Frame	FJG-1A-116	1
5	Bolt	-	2
6	Gasket	-	2
7	Squeezer Bearing	6203Z	2
8	Contact Roller	FJG-1A-142	2
9	Spindle	FJG-3A-143	2

## 6. Illustrations & Parts List

### 6.7 Conveyor Roller

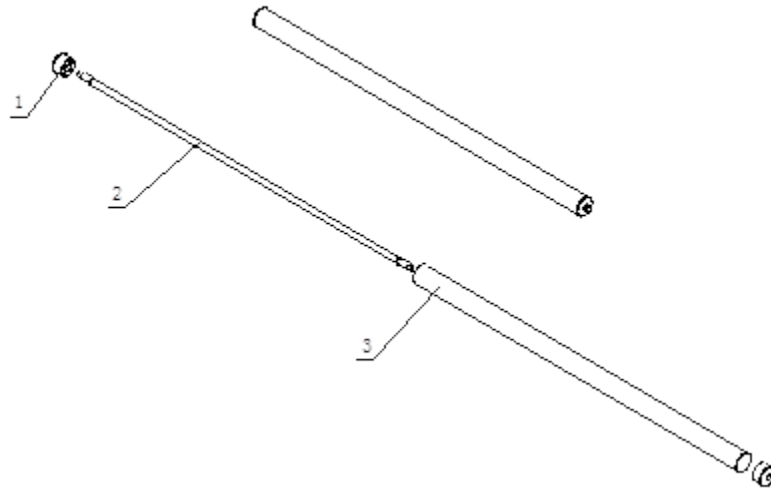

	Description	Part Number	Qty
1	Support Ring	FJG-1A-201	2
2	Long Shaft	FJG-1A-180	1
	Short Shaft	FJG-1A-181	1
3	Long Roller	FJG-1A-182	1
	Short Roller	FJG-1A-183	1

## 6.8 Tape Head

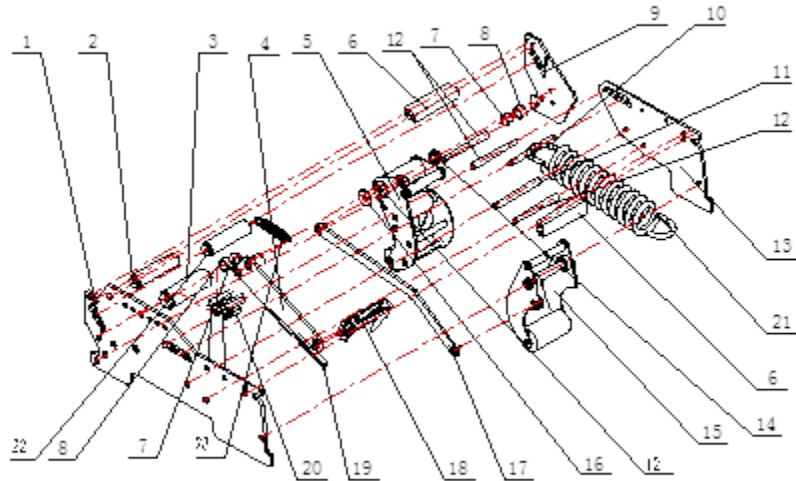
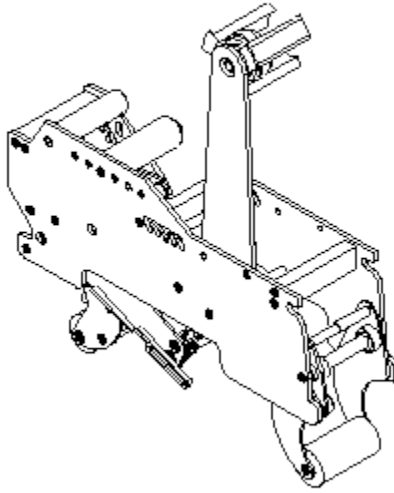

## 6. Illustrations & Parts List

### 6.8 Tape Head (Continued)

	Description	Part Number	Qty
1	Side Plate	FJ-01-17	1
2	Guide Pulley Assembly	-	1
3	One-Way Knurled Roller Assembly	-	1
4	Blade Carrier	FJ-01-04	1
5	Front Roller Assembly	-	1
6	Block	FJ-01-00	1
7	Shaft	FJ-00-12	2
8	Stop	FJ-40-00	2
9	Side Plate (x3)	FJ-01-02	1
10	Shaft	FJ-00-02	1
11	Shaft	FJ00-07	1
12	Shaft	FJ-00-06	4
13	Side Plate (x2)	FJ-01-16	1
14	Shaft Cover	FJ-02-09	1
15	Back Roller Side Plate Assembly	-	1
16	Brass Washer	FJ-02-04	1
17	Connecting Lever	FJ-01-14	1
18	Knife Back Plate Assembly	-	1
19	Knife Leveling Piece	FJ-01-01	1
20	Tape Hub Assembly	-	1
21	Extension Spring	FJ-H-07	1
22	Extension Spring Axis	FJ-00-01	1
23	Extension Spring	FJ-H-04	1

## 6. Illustrations & Parts List

### 6.9 Front Tape Roller Assembly

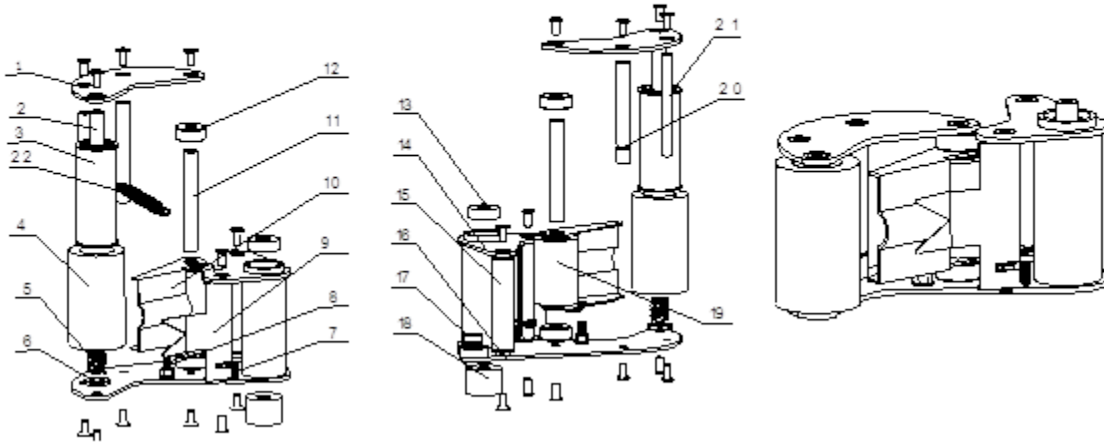

	Description	Part Number	Qty
1	Front Plate	FJ-01-09	1
2	Shaft	FJ-00-08	1
3	Roller Shaft	FJ-E-38-01	1
4	Idler Wheel	FJ-E-41-01	1
5	Press Spring	FJ-11-00	1
6	Gasket	FJ-50-100	1
7	Phillips Flat Head Screw	M4x12	1
8	Phillips Flat Head Screw	M5x15	1
9	Tape Holder Assembly	-	1
10	Tape Guide Assembly	FJ-01-08	1
11	Shaft	FJ-00-10	1
12	Axle Sleeve	FJ-02-02	2
13	Bearing	6900Z (1080900)	1
14	Front Roller	FJ-50-00	1
15	Guide Tape Wheel Assembly	-	1
16	Washer	-	1
17	Bearing	688Z (208088)	1
18	Bearing	7942/20	1
19	Axle Sleeve	FJ-02-10	1
20	Shaft	FJ-00-11	1
21	Shaft	FJ-00-09	1
22	Return Spring	FJ-H-00	1

## 6. Illustrations & Parts List

### 6.10 Back Roller Side Plate Assembly

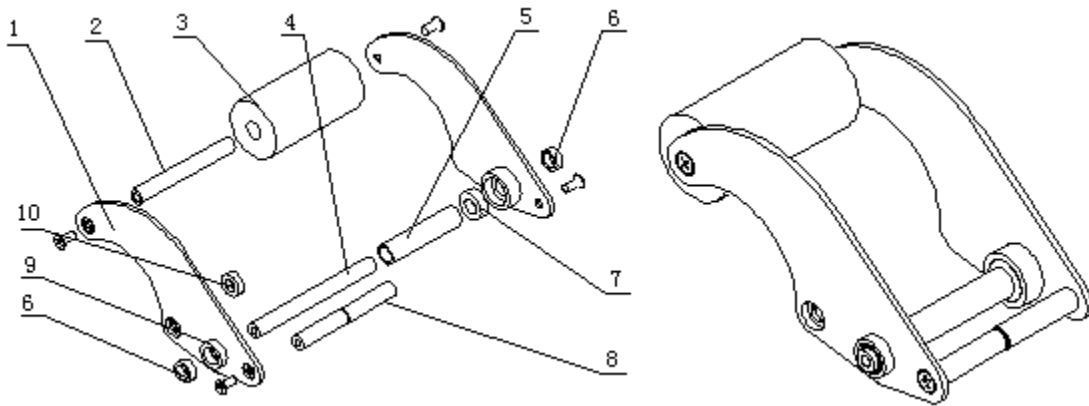

	Description	Part Number	Qty
1	Back Plate	FJ-01-13	1
2	Shaft	FJ-00-10	1
3	Idler Wheel	FJ-40-03	1
4	Shaft	FJ-00-06	1
5	Axle Sleeve	FJ-02-05	1
6	Axle Sleeve	FJ-02-06	2
7	Bearing	6800Z (26800)	2
8	Shaft	FJ-00-05	1
9	Axle Sleeve	FJ-02-00	1
10	Bearing	688Z (208088)	1

## 6. Illustrations & Parts List

### 6.11 One Way Knurled Roller Assembly

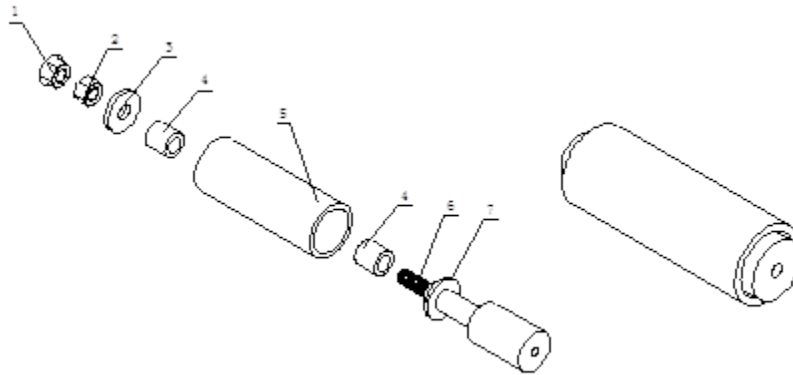

	Description	Part Number	Qty
1	Locknut	M8	1
2	Nut	M8	1
3	Washer	FJ-02-03	1
4	Bearing	HF1216	1
5	One Way Wheel	FJ-E-31-01	1
6	Shaft	FJ-00-04	1
7	Axle Sleeve	FJ-02-01	1

### 6.12 Guide Pulley Assembly

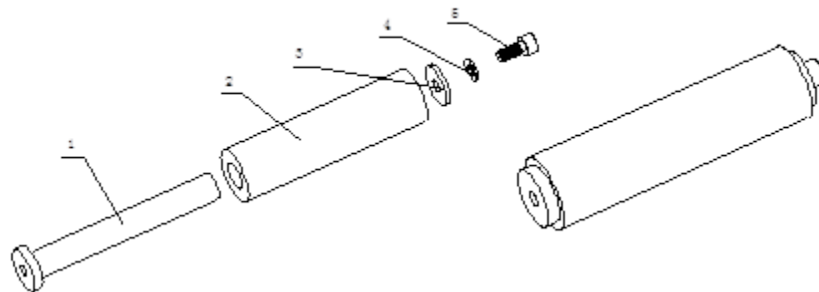

	Description	Part Number	Qty
1	Shaft	FJ-00-03	1
2	Axle Sleeve	FJ-02-07	1
3	Washer	5	1
4	Washer	5	1
5	Socket Head Cap Screw	M5x12	1



## 6. Illustrations & Parts List

### 6.13 Knife Back Plate Assembly

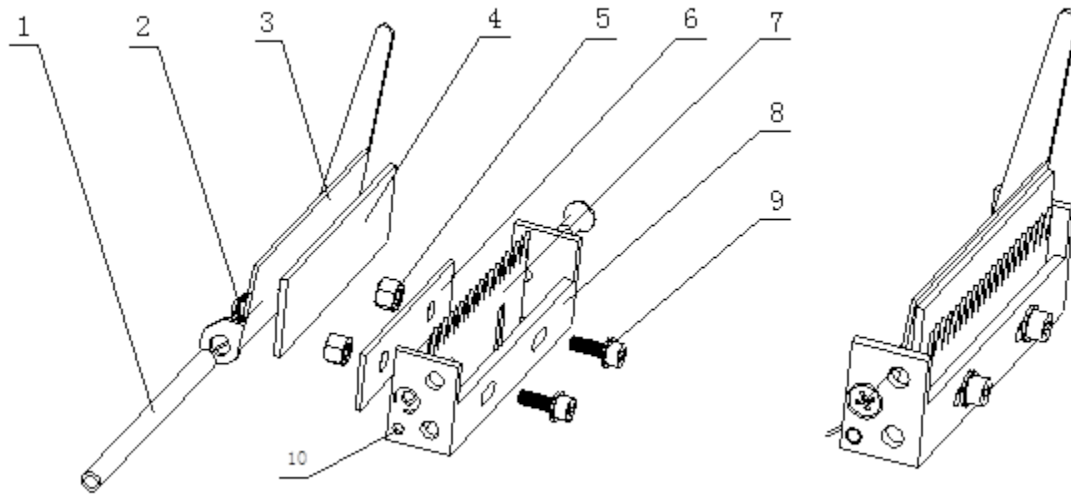

	Description	Part Number	Qty
1	Shaft	FJ-00-00	
2	Torsion Spring	FJ-H-05	
3	Protecting Blade Carrier	FJ-01-06	
4	Sponges	-	
5	Nut	M4	
6	Knife Board	FJ-40-04	
7	Blade	-	
8	Blade Carrier Block	FJ-01-07	
9	Socket Head Cap Screw	M4x16	
10	Phillips Flat Head Screw	M4x12	

## 6. Illustrations & Parts List

### 6.14 Tape Hub Assembly

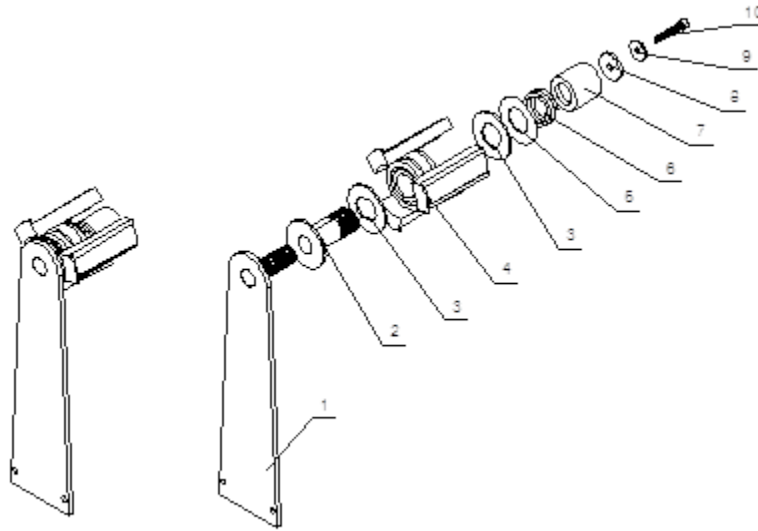

	Description	Part Number	Qty
1	Tape Frame	FJ-05-00	1
2	Axle Sleeve	FJ-02-12	1
3	Antiskid Slice	FJ-05-01	2
4	Tape Head Drum	FJ-02-05-03	1
5	Gasket	FJ-05-02	1
6	Press Spring	FJ-H-08	1
7	Shaft	FJ-00-14	1
8	Bearing Bush	FJ-02-08	1
9	Washer	5	1
10	Socket Head Cap Screw	M5x40	1

### 6.15 Guide Tape Wheel Assembly

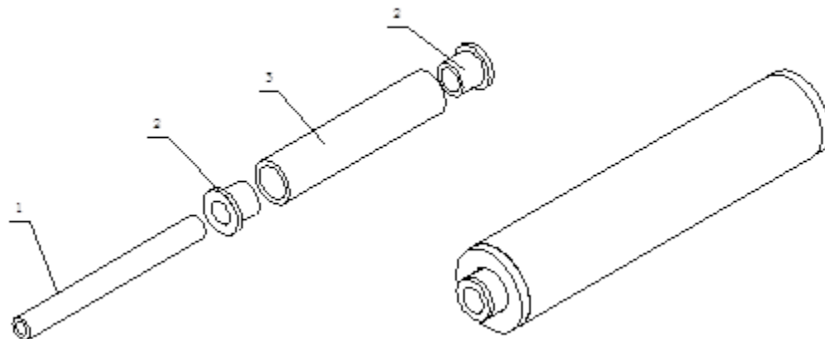

	Description	Part Number	Qty
1	Shaft	FJ-00-09	1
2	Axle Sleeve	FJ-02-14	2
3	Guide Tape Wheel	FJ-02-13	1

## 6. Illustrations & Parts List

### 6.16 Tape Holder Assembly

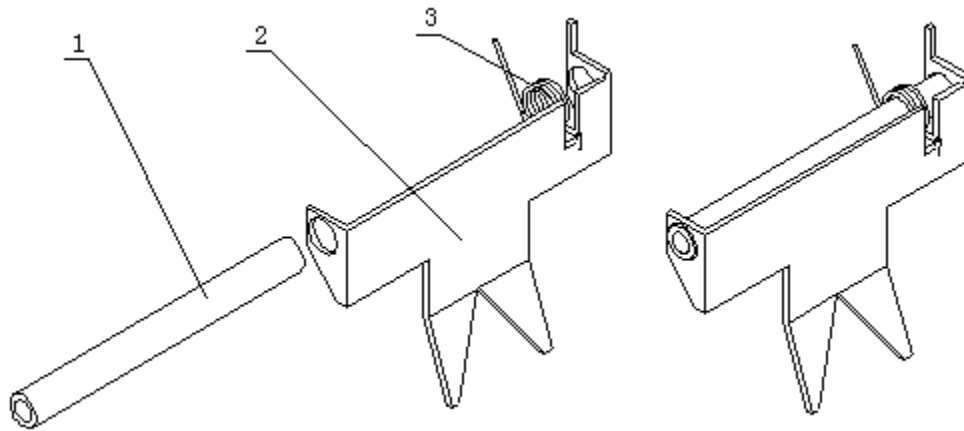

	Description	Part Number	Qty
1	Shaft	FJ-00-09	1
2	Press Tape Board	FJ-01-05	1
3	Torsion Spring	FJ-H-03	1

### 6.17 Tape Guide Assembly

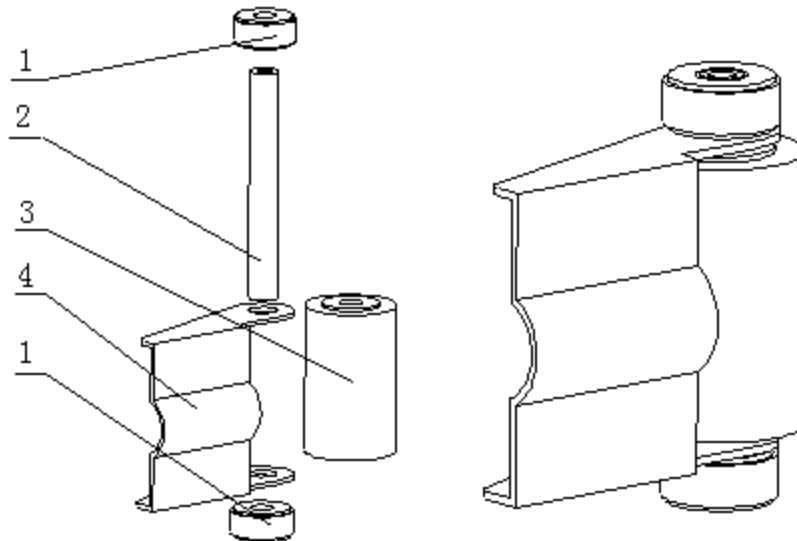

	Description	Part Number	Qty
1	Axle Sleeve	FJ-02-02	2
2	Shaft	FJ-00-10	1
3	Axle Sleeve	FJ-02-10	1
4	Press Board	FJ-01-08	1