

Introducing the **NEW**

## LM100

The LM100 (LogisticsMover) is specifically designed to move carts and cages where space, people and merchandise work closely together. Operators pushing and pulling loads in busy, fast and congested locations need smart machines to deliver safety and efficiency.



## Key Features

### Safety

- Anti-crush button and horn
- Secure coupling for load security
- Machine stop when controls disengaged, including on slopes

### Performance

- Dual high-powered motors for equal power distribution
- 180° steering angle for precision movement
- Move loads up to 2,205 lbs

### Quality

- Heavy-duty, maintenance-free battery
- Puncture-proof non-marking tires
- Tubular steel chassis and IP44 rating

### Power

- Interchangeable battery for 24/7 operation with fast charging
- Power display for real-time charge status
- Auto-switch off on full-charge to maximize battery life

### Connection

- Versatile multi-purpose coupling
- Custom coupling available
- Simple connection to items like carts and cages

## LM100 Technical specification

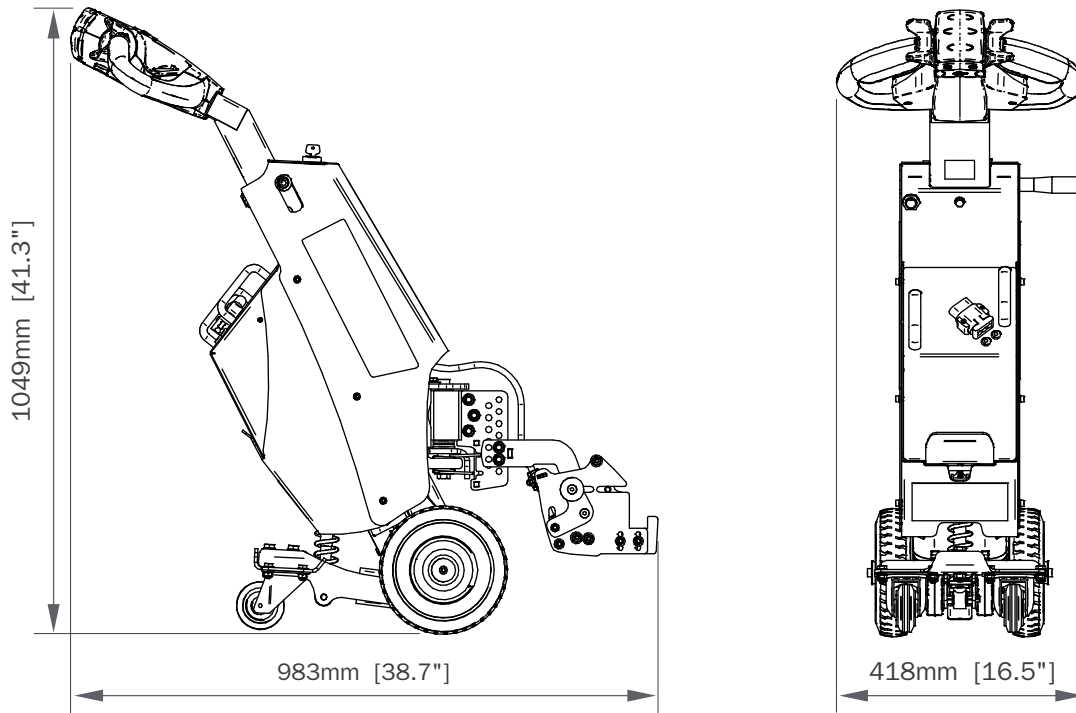

### LM100 Product data

Machine	Maximum Load	2,205 lbs
	Maximum Push Force (N)	981
	Maximum Pull Force (N)	981
	Connection	Cable
	Maximum Slope	30°
Opt	Two Speed Selector Switch	✓
Coupling	Custom Coupling Available	✓
	Roll Cage Link Bar	✓
	Xriss Xross Connection Straps	✓

Opt - Option